



NARRATED BY **KRISTEN BELL**

WILD AT HEART

AN
IMAX ORIGINAL FILM

PANDAS

Educational Activities

For Grades 4-8



WELCOME TO THE WORLD OF PANDAS

Pandas tells the amazing story of efforts to reintroduce *Ailuropoda melanoleuca*, the giant panda, from the Chengdu Research Base of Giant Panda Breeding in China back into the wild through a cross-cultural collaboration. Dr. Ben Kilham, Hou Rong, Dr. Jake Owens, Wenlei Bi, and the brave and curious Qian Qian (“chen chen”) join forces for this uplifting journey.

At the time of the 2014 census, Chinese scientists believed the mountainous bamboo forests of central and western China were home to a mere 1,864 giant pandas. Efforts had been underway for decades to protect the animals and their habitat, but attempts to raise and release wild cubs, or captive-bred cubs, were unsuccessful. In fact, by 1997, researchers felt that reintroducing pandas to the wild was not feasible as a result of too many failures. Recently, through the efforts of the Global Cause Foundation, Hou Rong enlisted the help of Dr. Kilham, who has successfully raised and reintroduced 165 black bears to the wilderness of New Hampshire.

Dr. Kilham’s detailed observations of the black bears’ social interactions, communication strategies, and cub-rearing may provide the necessary clues and methods to help the panda conservation center with their efforts.

After viewing *Pandas*, use the following hands-on, interactive lessons (suitable for grades 4 through 8) to inspire, educate and amaze your students.



ACTIVITIES OVERVIEW

4 NOT SO GIANT AT BIRTH! GROW-LIKE-A-PANDA MATH

The name *Ailuropoda melanoleuca* translates to “cat-foot” and “black and white.” The early Chinese referred to the giant panda as “giant bear cat” due, in part, to the cat-like pupils. The giant panda is nothing like a cat when it comes to growth, however. Discover the amazing variety of animal growth with this math activity.

8 BAMBOO BUFFET EAT-LIKE-A-PANDA MATH

Giant pandas eat a diet consisting mainly of bamboo, despite having the digestive system of a carnivore. How does the panda manage to get enough nutrients from bamboo despite these differences? By eating all day long! Calculate the food needs of a variety of animals compared to the food needs of the panda with this math activity.

12 I'M NOT LIKE YOU OUR CHALLENGES AND SUCCESSES

Dr. Kilham used his powers of observation to learn about the black bears in his care. He had hoped to continue with his college studies and earn an advanced degree, but his severe reading disability made this goal seem impossible at the time. He persevered, however, and found a way to fulfill his passion — reading nature, rather than words — and he eventually earned his PhD at Drexel University.

How important is it for us to accept the disabilities and challenges in ourselves or in others, and to find a way to succeed? Challenge students to find methods to understand, accept, compensate, and excel with the *I'm Not Like You!* activity.

15 COMMUNICATION WITHOUT WORDS SOCIAL INTERACTIONS INQUIRY

Dr. Kilham observed a complex system of verbal and non-verbal communication with the black bears he helped raise. Do giant pandas have similar forms of communication? We may not be able to study black bears as Dr. Kilham has, but we can observe our fellow humans. Challenge students to observe the effects of their non-verbal communications on others.

18 LISTEN TO MY EARS NON-VERBAL COMMUNICATION

Ears may be our message receivers, but for some animals, ears are also message senders. Dr. Kilham noted some of the same ear movement messages among black bears as have been seen with dogs, cats, horses, and other animals. Observe animals and create movable ears to mimic their movement while investigating the messages of ears. Read a passage from one of Dr. Kilham's books to explore this world of non-verbal communication.

26 WHAT DO YOU SEE? THE FINE ART OF FIELD OBSERVATION

Keen observation is at the heart of work for many field biologists. Dr. Kilham has spent years patiently watching animals and writing down what he observes. How keen are your observation skills? Watch a five-minute panda video and see how many details of animal behavior you see. Then, compare your observations to those of Dr. Jake Owens.

31 EASY DOES IT ANIMAL INTERACTIONS ACTIVITY FOR FAMILIES

Dr. Kilham makes interacting with wildlife look easy and safe. If he can do it, why can't we? Well, it is not safe to approach wild animals! Dr. Kilham has studied these animals for years. He lives by the idea of “Build Trust,” and he has learned, sometimes the hard way, to understand their “language” and their “rules.” While we cannot expect to approach any wild animal safely, we can use some of his methods to get closer to our safe wild neighbors, the birds and squirrels in our neighborhoods. Challenge students to work with their parents for a safe family-based experience.

34 GET CREATIVE

Continue your explorations into the world of the giant panda by challenging your students to create a panda craft project, such as an origami paper balloon panda, then by looking into the important panda research conducted by the Global Cause Foundation at www.gcause.org. How can we all help in the cause for the panda? Get involved!

NOT SO GIANT AT BIRTH!

GROW-LIKE-A-PANDA MATH

STUDENT ACTIVITY PG 1 OF 2

Name _____

Pandas start out as **TINY AS KITTENS!**

A ten-pound mother cat will give birth to a four ounce kitten. To simplify, let's convert to the metric system. Our 100 gram kitten will grow up to be a 4,500 gram adult cat. That's a 1:45 ratio. Dr. Kilham's black bear cubs are born at about 400 grams (14 ounces), then grow to be a healthy 100,000 grams (220 pounds) or more. That's a 1:250 ratio.

A giant panda, however, begins life at the same size as our kitten, but grows to be nearly the size of the black bear, from a 100 gram cub to a 90,000 gram (90 kilogram or 198 pound) adult. That's a staggering growth of 900 times its birth weight, a 1:900 ratio!



Credit: Hole in the Clouds



Credit: iStock/ksbank

If we all grew at the same rate as pandas, what would humans and animals weigh?

WEIGH IN!

Complete the chart for the animals on the next page, then do some research on baby animal birth weights and add your own critters to the chart. For scientific practice, be sure to convert to the metric system (1 pound = 453.6 grams), then practice converting between grams and kilograms by moving the decimal point. (Prefer pounds? Convert back, if desired.) Scientists use the metric system, which is known as the International System of Units (SI). Grams and kilograms are easier to use than ounces and pounds because of the simplicity of converting by moving the decimal point.

The giant panda and domestic cat, who both start life the size of a stick of butter, have been completed for you as examples, as has the human.

Note: All numbers are approximate, and have been simplified for this activity.

How would you feel if you met an animal growing in panda-style? Would you love this animal, or feel just a bit intimidated? Do the math, then analyze your results!

FOR FURTHER EXPLORATION

Create a bar graph to illustrate your results, showing the number of times greater than normal this new animal would grow.

You may also investigate the ratio of infant to normal adult for the animals by calculating full-grown weight divided by birth weight (90,000 g ÷ 100 g => a 1:900 ratio). Be sure to compute the brown bat's astounding ratio! That's a big baby for a tiny momma!

NOT SO GIANT AT BIRTH!

GROW-LIKE-A-PANDA MATH



STUDENT ACTIVITY PG 2 OF 2

Name _____

GROWTH CHART

All weights are approximate and numbers have been simplified for the purposes of this activity.

ANIMAL	Animal's birth weight in grams	Panda-growth-style adult weight in grams. Multiply birth weight by 900. Convert to kilograms (g ÷ 1000 = kg)	Animal's normal full-grown weight in grams (and kilograms)	Analysis: Bigger or smaller than normal? By how much? Panda-growth-style full-grown weight ÷ normal adult weight	Evaluation: How would you feel about meeting this new animal?!
A	B	C	D	E	F
GIANT PANDA	100 g	$100 \text{ g} \times 900 = 90,000 \text{ g}$ or 90 kg	90,000 g 90 kg	same	😊
CAT	100 g	$100 \text{ g} \times 900 = 90,000 \text{ g}$ or 90 kg	4,500 g 4.5 kg	$90,000 \text{ g} \div 4500 \text{ g} = 20$ times bigger	Yikes! This kitty is not sleeping on my bed!
HUMAN	3,400 g	$3,400 \text{ g} \times 900 = 3,060,000 \text{ g}$ or 3,060 kg	80,000 g 80 kg	$3,060,000 \div 80,000 = 38.25$ times bigger	Wow! At 38.25 times my weight, I'd be as heavy as a rhinoceros!
BLACK BEAR	400 g		100,000 g 100 kg		
BENGAL TIGER	1,200 g		200,000 g 200 kg		
ELEPHANT	90,000 g		4,050,000 g 4,050 kg		
RABBIT	80 g		3,000 g 3 kg		
ORCA	180,000 g		4,000,000 g 4,000 kg		
GIRAFFE	50,000 g		1,000,000 g 1,000 kg		
HORSE	68,000 g		680,000 g 680 kg		
BROWN BAT	5.75 g		23 g 0.023 kg		
RED KANGAROO	.75 g		90,000 g 90 kg		



CONVERSION TABLE

$\text{g} \div 1000 = \text{kg}$
 $\text{kg} \times 1000 = \text{g}$

$\text{grams} \times 0.0022 = \text{pounds (lb)}$
 $\text{kilograms} \times 2.2 = \text{pounds (lb)}$

$\text{lb} \times 453.592 = \text{grams}$

NOT SO GIANT AT BIRTH!

GROWTH CHART

ANIMAL	Animal's birth weight in grams	Panda-growth-style adult weight in grams. Multiply birth weight by 900. Convert to kilograms (g ÷ 1000 = kg)	Animal's normal full-grown weight in grams (and kilograms)	Analysis: Bigger or smaller than normal? By how much? Panda-growth-style full-grown weight ÷ normal adult weight	Evaluation: How would you feel about meeting this new animal?!
A	B	C	D	E	F
GIANT PANDA	100 g	$100 \text{ g} \times 900 = 90,000 \text{ g}$ or 90 kg	90,000 g 90 kg	same	😊
CAT	100 g	$100 \text{ g} \times 900 = 90,000 \text{ g}$ or 90 kg	4,500 g 4.5 kg	$90,000 \text{ g} \div 4500 \text{ g} = 20$ times bigger	Yikes! This kitty is not sleeping on my bed!
HUMAN	3,400 g	$3,400 \text{ g} \times 900 = 3,060,000 \text{ g}$ or 3,060 kg	80,000 g 80 kg	$3,060,000 \div 80,000 = 38.25$ times bigger	Wow! At 38.25 times my weight, I'd be as heavy as a rhinoceros!
BLACK BEAR	400 g	360,000 g	100,000 g 100 kg	3.6 times bigger	<i>student responses...</i>
BENGAL TIGER	1,200 g	1,080,000 g	200,000 g 200 kg	5.4 times bigger	
ELEPHANT	90,000 g	81,000,000 g	4,050,000 g 4,050 kg	20 times bigger	
RABBIT	80 g	72,000 g	3,000 g 3 kg	24 times bigger	
ORCA	180,000 g	162,000,000 g	4,000,000 g 4,000 kg	40.5 times bigger	
GIRAFFE	50,000 g	45,000,000 g	1,000,000 g 1,000 kg	45 times bigger	
HORSE	68,000 g	61,200,000 g	680,000 g 680 kg	90 times bigger	
BROWN BAT	5.75 g	5,175 g	23 g 0.023 kg	225 times bigger	
RED KANGAROO	.75 g	675 g	90,000 g 90 kg	0.0075 SMALLER!	

NOT SO GIANT AT BIRTH!

GROWTH GRAPH

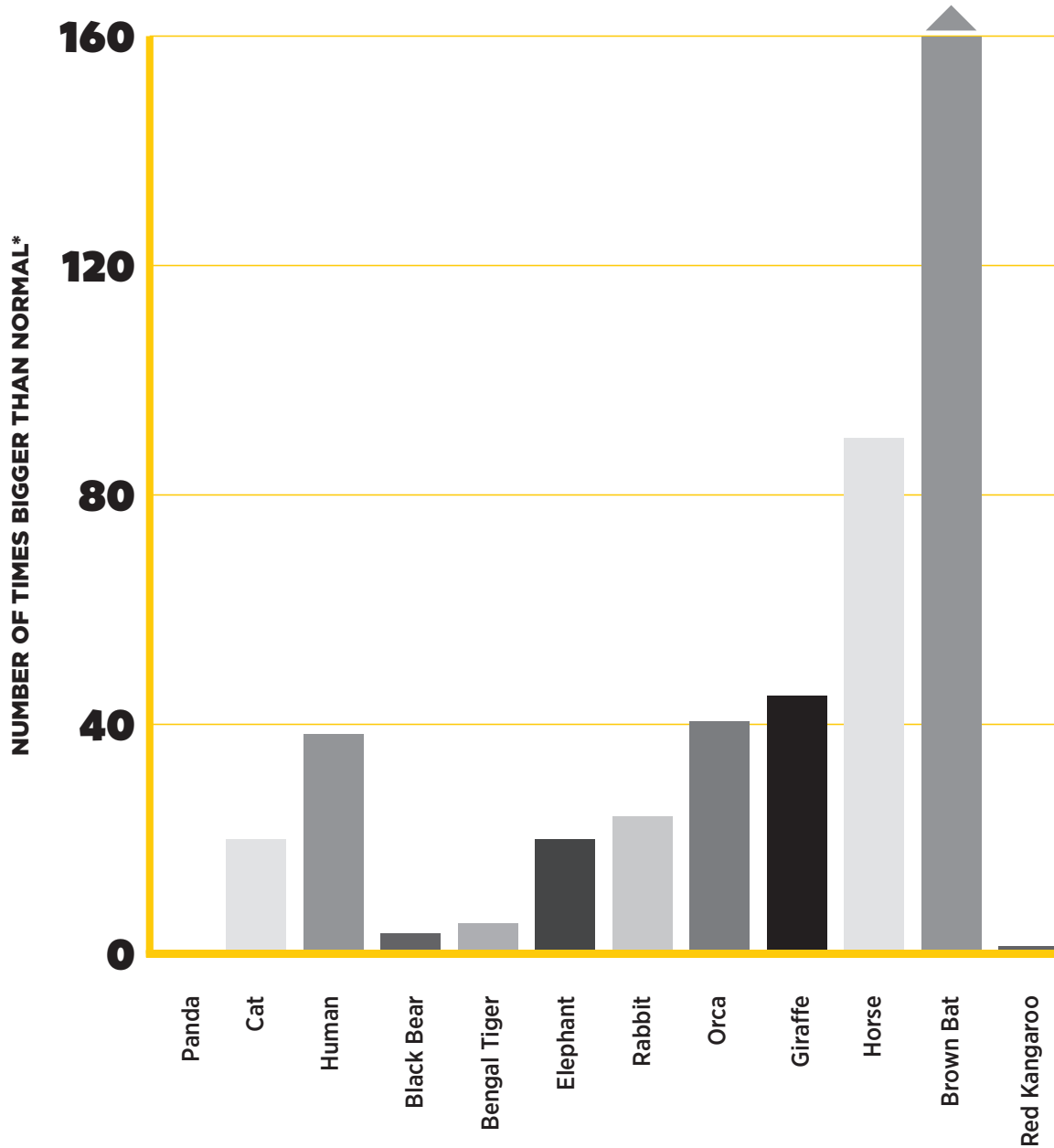

*For example, if the cat grew like a panda, it would be 20 times its normal size

BAMBOO BUFFET!

EAT-LIKE-A-PANDA MATH

STUDENT ACTIVITY PG 1 OF 2

Name _____

Pandas eat
**ALL DAY
LONG!**

Giant pandas eat a diet consisting mainly of bamboo, despite having the digestive system of a carnivore. A proper herbivore, such as a sheep, has a gut measuring 25 times its body length. This long system allows

the sheep to extract a good amount of nutrients from the nutrient-poor diet of grass it consumes, thanks to the billions of bacteria which aid in digestion of the

cellulose. Those bacteria, when digested by the sheep in the final bits of the intestine, provide nutritious animal proteins. Pandas, on the other hand, have the simpler system of their bear relatives and other carnivores or omnivores, including humans. Carnivores have very little bacteria in their guts in comparison with herbivores, and the gut is a mere six-times the body length, rather than 25. How does the panda manage to get enough nutrients from the bamboo despite these differences? By eating all day long!

If we all ate like a panda, as in the same number of grams of bamboo per kilograms of body weight, how much bamboo would humans and other animals eat?

BON APPETIT!

Complete the chart for the animals on the following page, then analyze your results. How would you feel if you had to feed an animal at the Bamboo Buffet? The giant panda, cat, and human have been completed for you as examples.

Next, do some research on animal diets and add your own critters to the chart, but, for scientific practice, be sure to convert to the metric system. (Prefer pounds? Convert back, if desired.) Scientists use the metric system, which is also known as the International System of Units (SI). Grams and kilograms are easier to use than ounces and pounds because of the simplicity of converting by moving the decimal point.

For further explorations, graph your results, and compare them to your results from the Grow-Like-a-Panda Math. Which animals are carnivores, and which are herbivores? This could result in lots of "Zoo Doo" to fertilize our gardens!



An interesting note: 16,000 grams of bamboo (as noted for the human in the chart) will not provide a human with much nutrition, but 16,000 grams of raw broccoli would fill over 222 cups, and would provide us with over 4,440 calories – over three times as many calories as a ten year old may require, and twice as many calories as adults require!

BAMBOO BUFFET!

EAT-LIKE-A-PANDA MATH

STUDENT ACTIVITY PG 2 OF 2

Name _____

CONSUMPTION CHART

All weights are approximate and numbers have been simplified for the purposes of this activity.

ANIMAL	Normal full-grown weight in kilograms	Amount of food consumed daily in grams	What is the amount of food consumed daily in grams per kilograms of body weight (g/kg)?	At the Bamboo Buffet, if the animal ate panda-style consuming 200 grams of bamboo for each kilogram of its own weight, how much bamboo would it have to eat per day? (200 x normal full-grown weight = grams of food)	Evaluation: Compare Bamboo Buffet results to the animal's normal g/kg of food. How would you feel about feeding this animal?!
A	B	C	D	E	F
GIANT PANDA	90 kg	18,000 g	$18,000 \text{ g} \div 90 \text{ kg} = 200 \text{ g/kg}$	$200 \text{ g/kg} \times 90 \text{ kg} = 18,000 \text{ g}$	😊
CAT	4.5 kg	65 g	$65 \text{ g} \div 4.5 \text{ kg} = 14.44 \text{ g/kg}$	$200 \times 4.5 = 900 \text{ g}$	Yikes! That's nearly half of what a human normally eats!
HUMAN	80 kg	2,500 g	$2,500 \text{ g} \div 80 \text{ kg} = 31.25 \text{ g/kg}$	$200 \times 80 = 16,000 \text{ g}$	Wow! I'd be eating all day long!
BLACK BEAR	100 kg	3,900 g			
RABBIT	3 kg	180 g			
RED KANGAROO	90 kg	1,300 g			
BENGAL TIGER	200 kg	20,000 g			
HORSE	680 kg	10,000 g			
GIRAFFE	1,000 kg	66,000 g			
ORCA	4,000 kg	130,000 g			
ELEPHANT	4,000 kg	130,000 g			
BROWN BAT	0.023 kg	12 g (1000 mosquitoes per hour)			



CONVERSION TABLE

$\text{g} \div 1000 = \text{kg}$
 $\text{kg} \times 1000 = \text{g}$

$\text{grams} \times 0.0022 = \text{pounds (lb)}$
 $\text{kilograms} \times 2.2 = \text{pounds (lb)}$

$\text{lb} \times 453.592 = \text{grams}$

BAMBOO BUFFET!

CONSUMPTION CHART

ANIMAL	Normal full-grown weight in kilograms	Amount of food consumed daily in grams	What is the amount of food consumed daily in grams per kilograms of body weight (g/kg)?	At the Bamboo Buffet, if the animal ate panda-style consuming 200 grams of bamboo for each kilogram of its own weight, how much bamboo would it have to eat per day? (food g ÷ weight kg = g/kg)	At the Bamboo Buffet, if the animal ate panda-style consuming 200 grams of bamboo for each kilogram of its own weight, how much bamboo would it have to eat per day? (200 x normal full-grown weight = grams of food)	Evaluation: Compare Bamboo Buffet results to the animal's normal g/kg of food. How would you feel about feeding this animal?!
A	B	C	D	E	F	
GIANT PANDA	90 kg	18,000 g	$18,000 \text{ g} \div 90 \text{ kg} = 200 \text{ g/kg}$	$200 \text{ g/kg} \times 90 \text{ kg} = 18,000 \text{ g}$		
CAT	4.5 kg	65 g	$65 \text{ g} \div 4.5 \text{ kg} = 14.44 \text{ g/kg}$	$200 \times 4.5 = 900 \text{ g}$	Yikes! That's nearly half of what a human normally eats!	
HUMAN	80 kg	2,500 g	$2,500 \text{ g} \div 80 \text{ kg} = 31.25 \text{ g/kg}$	$200 \times 80 = 16,000 \text{ g}$	Wow! I'd be eating all day long!	
BLACK BEAR	100 kg	3,900 g	39 g/kg	20,000 g	<i>student responses...</i>	
RABBIT	3 kg	180 g	60 g/kg	600 g		
RED KANGAROO	90 kg	1,300 g	14.44 g/kg	18,000 g		
BENGAL TIGER	200 kg	20,000 g	100 g/kg	40,000 g		
HORSE	680 kg	10,000 g	14.7 g/kg	136,000 g		
GIRAFFE	1,000 kg	66,000 g	66 g/kg	200,000 g		
ORCA	4,000 kg	130,000 g	32.5 g/kg	800,000 g		
ELEPHANT	4,000 kg	130,000 g	32.5 g/kg	800,000 g		
BROWN BAT	0.023 kg	12 g (1000 mosquitoes per hour)	521.7 g/kg	4.6 g		

BAMBOO BUFFET!

CONSUMPTION GRAPH

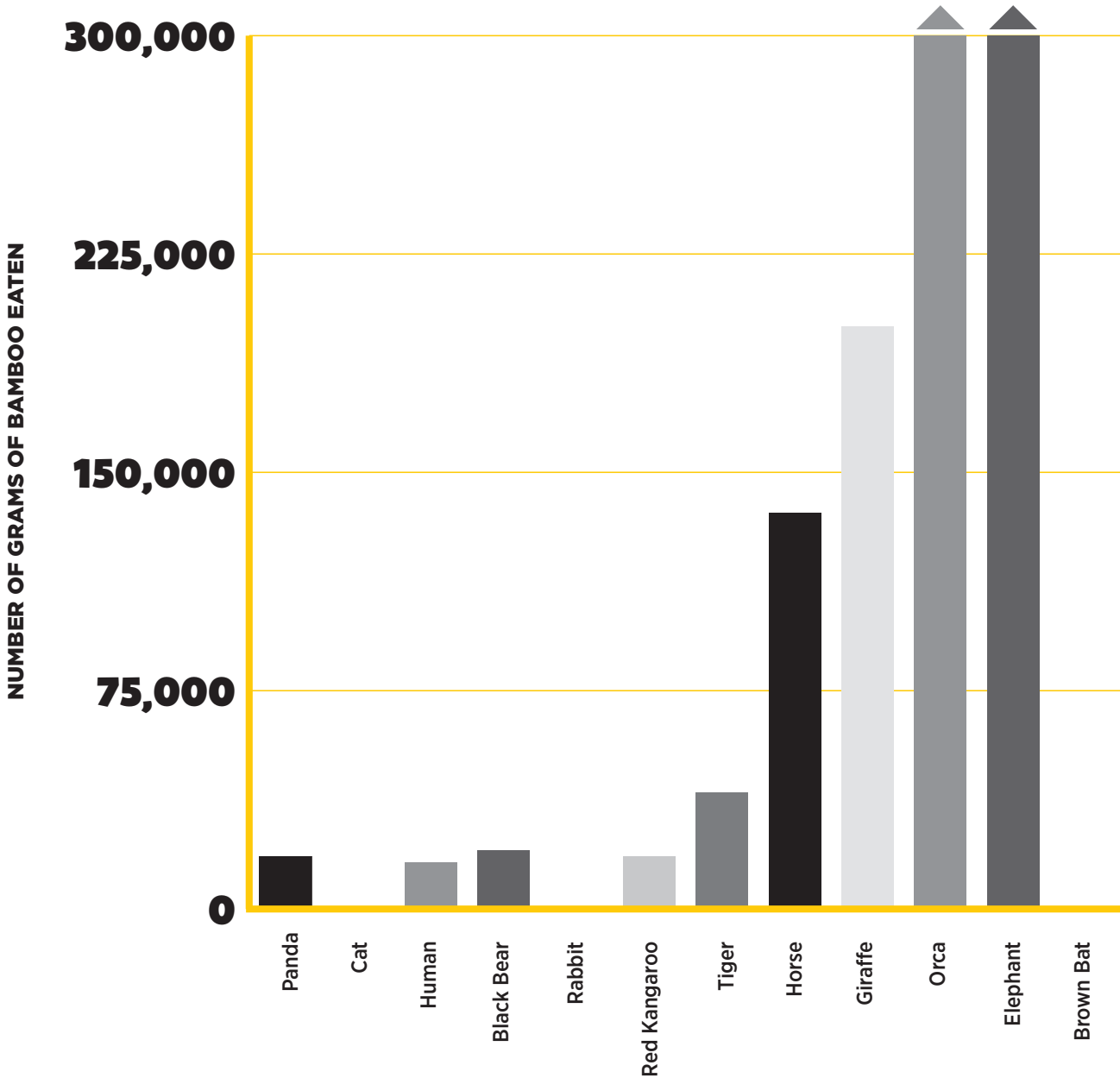

*Cat, rabbit and brown bat amounts are too small to see on this scale.

I'M NOT LIKE YOU!

OUR CHALLENGES AND SUCCESSES

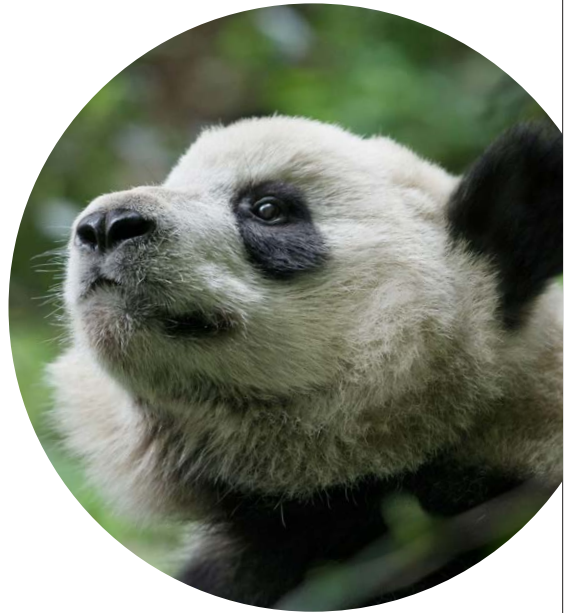

HOW DO WE ACCEPT OTHERS' DIFFERENCES AND HELP THEM TO SUCCEED?

EDUCATOR INFORMATION

Dr. Kilham used his powers of observation to learn about the black bears in his care. He had hoped to continue with his college studies and earn an advanced degree, but his severe reading disability made that plan seem impossible at the time. He persevered, however, and found a way to fulfill his passion — reading nature, rather than words — and he eventually earned his PhD at Drexel University. He did so because he found friends to help him at the Global Cause Foundation and Drexel University.

His friend and mentor, Dr. James R. Spotila, helped him to open the doors to graduate school based on the value of his 25 years of independent research.

Together they were able to see him through to earn his PhD. How important is it for us to accept the disabilities and challenges in ourselves or in others, and to find a way to succeed? How important is it for friends to help each other to succeed?

Take a look at the posters provided online showing the giant panda and the black bear. Challenge students to find methods to understand, accept, compensate, and excel with the **I'm Not Like You!** activity.



Visit pandas.IMAX.com to download these posters

I'M NOT LIKE YOU!

OUR CHALLENGES AND SUCCESSES



STUDENT ACTIVITY PG 1 OF 2

Name _____

Imagine you are a **BLACK BEAR.**

You excel at finding and eating your favorite foods — buds of beech trees, flowers of red maple, leaves of wild lettuce, berries of blackberry or blueberry or huckleberry. Then, in the

fall, you feast on acorns or beechnuts. You also eat ants, grubs and other insects for their protein, and you even occasionally succeed in hunting for baby birds, migrating salmon, or even a young deer. You are good at hiding in the dark woods and hibernating through the snowy winters.



How would you feel if you went to visit your giant panda relatives in the mountains of China, where you would find fewer than **2,000 bears** in a habitat smaller than the state of New Hampshire (Dr. Kilham's home state)? What aspects of the panda's life would you find **challenging**? Where might you **excel**? What strategies could you use to **compensate** and **succeed**?



Imagine you are a **GIANT PANDA.**

You manage to thrive on your diet of bamboo by eating both tender leaves and splintery stalks for a grueling fourteen hours a day. You have a special lining in your throat that protects it from the rough wood, and a specialized wrist bone that

acts as a thumb to hold the bamboo as your tough teeth grind through it. You have enormous jaw bones, plus a crest on the top of your skull to hold the massive muscles you need to chew your woody meal. You cannot put on enough fat to be able to hibernate through the winter, so you simply move down the mountain to warmer areas and other species of bamboo to survive. Like your black bear relatives you are good at climbing trees, but with a somewhat slower metabolism you rarely move quickly.



How would you feel if you went to visit your black bear relatives in North America, where you would find over **750,000 black bears**, ranging from Canada to Mexico? What aspects of the black bear's life would you find **challenging**? Where might you **excel**? What strategies could you use to **compensate** and **succeed**?



I'M NOT LIKE YOU!

OUR CHALLENGES AND SUCCESSES



STUDENT ACTIVITY PG 2 OF 2

Name _____

BEAR WITH IT

1. Work with your group to identify challenges and ways to compensate, both for black bears and for pandas.
2. How are these challenges similar to the challenges Dr. Kilham may have felt growing up with dyslexia, a reading disorder? How do you think he was able to compensate?
3. Think about people you know with other disabilities. How do they compensate?
4. How could you help those with disabilities to feel more comfortable and successful?
5. How can you improve your abilities to understand, accept, compensate, and excel? How can you help your friends?

CHALLENGES

BLACK BEARS



WAYS TO COMPENSATE

CHALLENGES

GIANT PANDAS



WAYS TO COMPENSATE

COMMUNICATION WITHOUT WORDS

SOCIAL INTERACTIONS INQUIRY

HOW DO NON-VERBAL EXPRESSIONS AFFECT THE EXPRESSIONS OF OTHERS?

EDUCATOR INFORMATION

Dr. Kilham observed a complex system of verbal and non-verbal communication among the black bears he raised. He learned that the “mmm-mmm-mmm” vocalization is a non-threatening greeting, but the “huh-huh-huh” vocalization is “the human equivalent of a chewing-out.” They are very similar, but the mouth-open utterance gives the opposite meaning from the mouth-closed utterance.

While caring for his bears he also learned to respect the non-verbal cues of the straight-legged walk, the twitching eye, or the gentle bite. Dr. Kilham wrote, “I’ve even found a great deal of similarity between human facial expressions and those of bears. There is no doubt a bear’s expressions are harder to read, because of the facial differences, but they are there: Smiles are smiles and frowns are frowns.”

[Kilham, B. (2013). *In the Company of Bears*, Chelsea Green Publishing, White River Junction, Vermont] p. 65

Challenge students to observe the effects of their non-verbal communications on others, either at school or with their families. Allow students to create their own inquiry, or provide a more directed activity using the following page for guidance. Explain to students that experiments involving other humans require consent from the subjects, so plan on working with a partner class and agree to consent to no-risk social research.

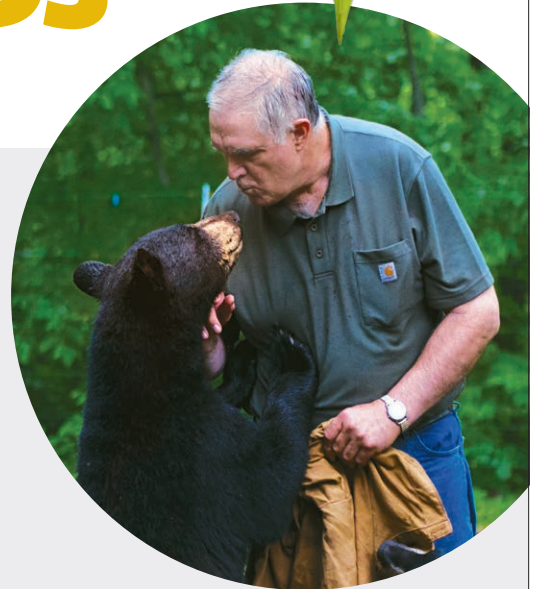

Black bear greeting Dr. Kilham in “bear style” by sniffing his breath.



More information for students on experimenting with human subjects can be found on the Science Buddies website: www.sciencebuddies.org/science-fair-projects/competitions/human-subjects-regulations

COMMUNICATION WITHOUT WORDS

SOCIAL INTERACTIONS INQUIRY



STUDENT ACTIVITY PG 1 OF 2

Name _____

FACE OFF!

QUESTION:

How do non-verbal expressions, such as smiles and frowns, affect the expressions of others?

HYPOTHESIS:

I predict that smiling and frowning, while making eye contact, will affect others in the following way (*choose one*):

- ☺ → ☺ _____ More than half will respond with the same expression.
- ☺ → ☹ _____ More than half will respond with the opposite expression.
- ☺ → 😐 _____ More than half will not respond.

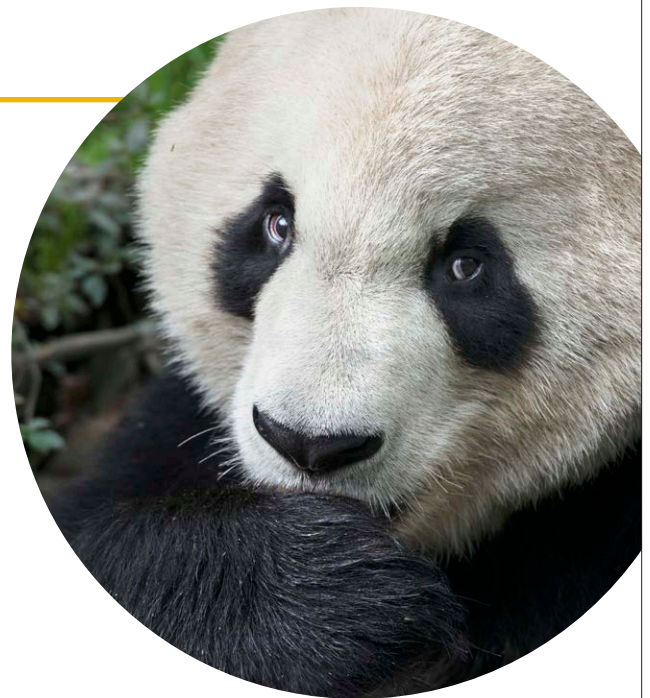

If I smile,
WILL YOU SMILE?

PROCEDURE:

In teams of three or four, designate one teammate as the Communicator, and the others as Data Collectors. Work with a partner class who agrees to take part in a no-risk social experiment, but do not explain the experiment. Instead, explain that the two classes will walk around and mingle, just being aware of each other.

For the actual experiment, the Communicator will make eye contact with a subject, randomly choose either the smile or the frown, then Data Collectors will record the responses.

Data Collectors should be careful to maintain a neutral face (what Dr. Kilham refers to as a “subway face,” which is what he recommends we all use when confronted by a black bear, but we need to understand *their* expressions and non-verbal cues if we’d like to survive the encounter!).

COMMUNICATION WITHOUT WORDS

SOCIAL INTERACTIONS INQUIRY

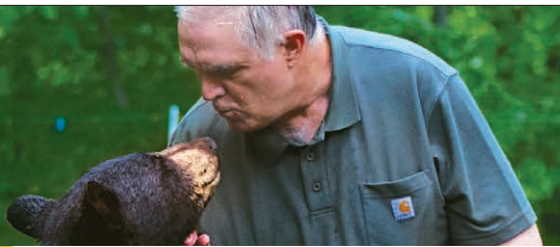

STUDENT ACTIVITY PG 2 OF 2

Name _____

RESULTS:

How did subjects respond? Did more subjects return the same expression, or the opposite expression?



CRITICAL THINKING:

Discuss these questions with your team.

- What part of your experiment, or what variable, affected responses the most?
- How important do you feel non-verbal forms of communication are in social situations?
- What would happen if we were unable to perceive non-verbal communications from others?
- How would a challenge, such as blindness or autism spectrum disorder, affect non-verbal communication?
- How might we learn to compensate for those challenges?

LISTEN TO MY EARS

NON-VERBAL COMMUNICATION ACTIVITIES

HOW DO ANIMALS' EARS COMMUNICATE?

EDUCATOR INFORMATION

Ears may be our message receivers, but, for some animals, ears are also message senders. Dr. Kilham noted some of the same ear position messages among black bears as can be seen with dogs, cats, horses, and other animals. The giant panda has not been observed communicating with ear movement, possibly due to ears that lack the flexibility to flatten. For those animals that *can* move their ears, what messages can they effectively communicate?

In the following activities students will experience how ear positions can send messages and illicit different responses.

ACTIVITY 1 “EARS OF EXPERIENCE” Students will create a headband with moveable ears, then record how others interpret what each ear position might be communicating.

ACTIVITY 2 “I HEAR YA!” After students read an excerpt from Dr. Kilham’s book *In the Company of Bears*, lead them in a discussion using the thought-provoking questions provided.

FAMILY ACTIVITY “THE EARS TELL ALL” Challenge students to continue their investigations during family time. With a parent, observe dogs interacting with other animals, either in a dog park, in homes, or even in a dog training class at a pet store or other facility.

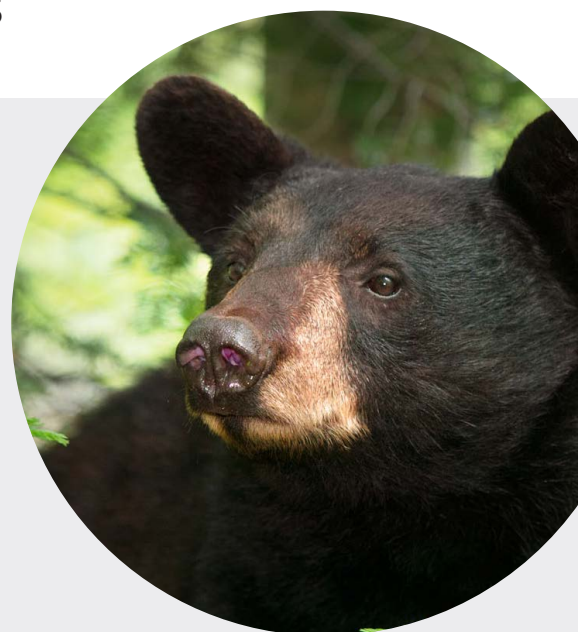

LISTEN TO MY EARS

NON-VERBAL COMMUNICATION

STUDENT ACTIVITY 1 PG 1 OF 3

Name _____

Create a pair of **BEAR EARS**

Using sturdy card stock or construction paper, create a pair of ears, either bear ears or upright dog ears. See the pattern on page 21 as a suggestion. Attach the ears to a paper headband — a

band of paper wrapped around your head, with another band over the top of the head for the ears. If possible, attach the ears using brass brads or paper fasteners to allow the ears to rotate. Paper clips can allow the ears to be held back in a flattened position.

Move the ears into various positions:

- **Ears facing forward**
- **Ears facing outward**
- **One ear forward and the other back**
- **Ears cocked to the sides**
- **Ears flattened backward.**

Wear the ears in these various positions and interview others to learn how they might interpret the messages.



Note: Animals do not “choose” to use their ears. It is an instinctual response that has evolved through natural selection. The bear or dog is not thinking “I will point my ears down now.” They just do it, and the ability to communicate in this way has given them an evolutionary advantage over many generations.

EARS OF EXPERIENCE



QUESTION:

How will ear position be understood by the students in another class, and can the position of an animal's ears be interpreted as a message of friendliness or of aggression?

HYPOTHESIS:

I predict that the position of an animal's ears...

(choose one) _____ will _____ will not

...be interpreted as a message of friendliness or of aggression by my test subjects.



LISTEN TO MY EARS

NON-VERBAL COMMUNICATION

STUDENT ACTIVITY 1 PG 2 OF 3

Name _____

PROCEDURE:

Create a movable-ear headband using construction paper and paper fasteners. Use two of the straight strips to create a band that fits around your head (add paper if necessary to lengthen) and secure with tape. Then secure the third strip to fit over the top as a headband. Cut two matching ears. Fold on the dotted line, then cut a slit in the center of this bottom tab to allow the ear to fold in, overlapping the center of the tab. Punch a hole through the overlapped area of the tab and another through the headband, then fix the ears onto the headband using paper fasteners. If paper fasteners are not available, tape the ears into position in a way that will allow them to be movable.

Rotate the ears forward or out to the sides, or use paper clips to hold the ears in a backward-facing pinned-down position.

Work in teams, positioning the ears into various positions, especially the forward-facing position and the backward-facing pinned-down position. Demonstrate the different positions for several people who agree to take part in your experiment, and ask them to choose which ear position conveys a message of friendliness and which conveys a message of aggression. Ask, "When the ears are placed this way, do I look friendly, aggressive, curious, or none of these?"

RESULTS:

How did the people you questioned respond? Did more people feel the forward-facing ears were friendly or aggressive? Or did they feel the ears did not convey an emotion?

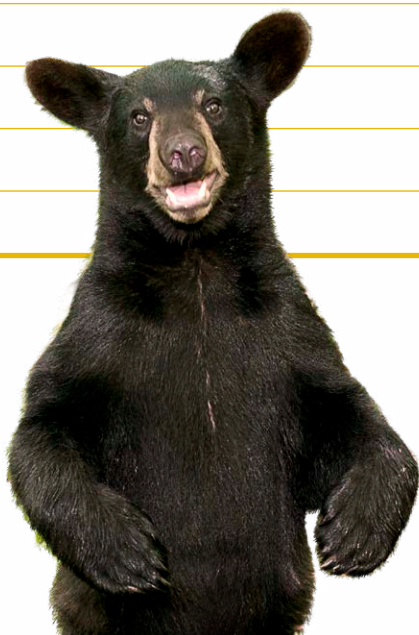

CRITICAL THINKING:

Discuss these questions with your team.

- Why do animals use their ears to convey emotion?
- In what ways would this be helpful to them?
- In what ways is it helpful for humans to be aware of this form of non-verbal communication from animals?

EARS OF EXPERIENCE

STUDENT ACTIVITY 1 PG 3 OF 3

For best results print this page and use as a stencil to create the ears headband from construction paper (or cardstock).

You will need:

- Scissors
- Tape
- Paper fasteners
- Construction paper
- Hole punch
- Paper clips

Directions:

1. Use two of the straight strips to create a band that fits around your head (add paper if necessary to lengthen) and secure with tape. Then secure the third strip to fit over the top as a headband.
2. Cut two matching ears. Fold on the dotted line, then cut a slit in the center of this bottom tab to allow the ear to fold in, overlapping the center of the tab. Punch a hole through the overlapped area of the tab and another through the headband, then fix the ears onto the headband using paper fasteners.

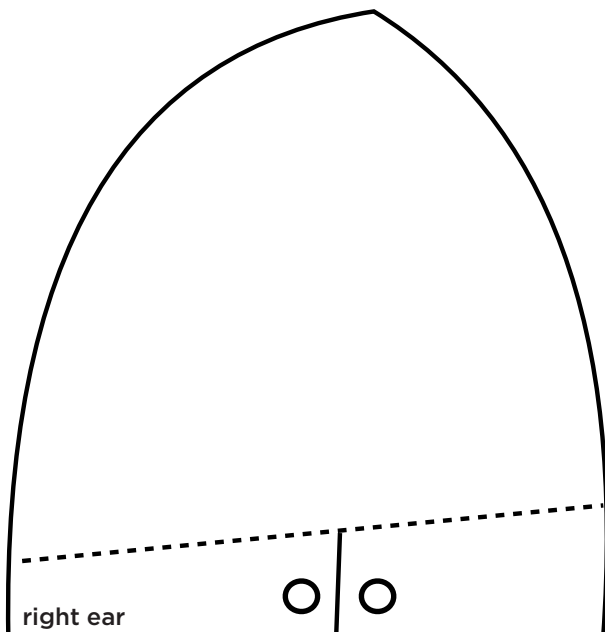
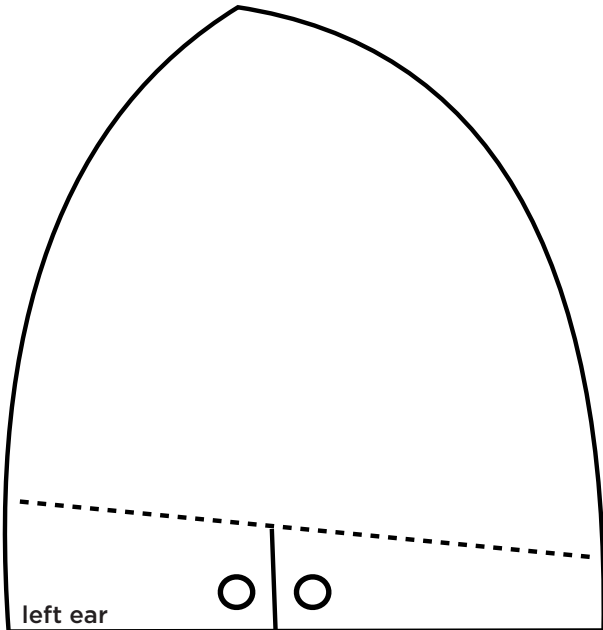



LISTEN TO MY EARS

NON-VERBAL COMMUNICATION

STUDENT ACTIVITY 2 PG 1 OF 2

Name _____

Read this selection from Dr. Kilham's book *In the Company of Bears* (formerly titled *Out on a Limb*), then discuss the passage as a class using the questions on the following page.

Bears' ears can **SAY SO MUCH!**

Ear position, too, can clue an onlooker in to what a bear is experiencing or feeling. In fact, the way bears communicate with their ears is similar to the way horses and deer do. Bears have both functional and emotional ear movements. Some ear movements simply allow them to stay alert to sound. When they are eating, for instance, the very act of chewing creates noise, which compromises their ability to pick up other sounds around them. So they rotate their ears outward, with the openings opposite each other, for maximum coverage in picking up sounds. While investigating sounds or when alerted to scent, they rotate their ears forward in the direction of the sound or smell. When stalking another bear, their ears are also cocked forward.

Other ear positions, though, act out a kind of emotional sign language for bears. When they're approaching aggressively or attacking, their ears are pinned to the back of their neck. When irritated, their ears are half-cocked. A cautious but curious bear may have one ear back and one ear forward. Their ears may change position rapidly, reflecting rapidly changing moods.

[Kilham, B. (2013). *In the Company of Bears*, Chelsea Green Publishing, White River Junction, Vermont.] p. 67

LISTEN TO MY EARS

NON-VERBAL COMMUNICATION

STUDENT ACTIVITY 2 PG 2 OF 2

Name _____

I HEAR YA!

Questions to Discuss:

- | | |
|---|--|
| <ul style="list-style-type: none">1. What is the difference between functional and emotional movements of the ears?2. How might Dr. Kilham have realized that black bears rotate their ears to focus on sounds while eating?3. Why do you think bears need to listen while eating?4. Some scientists believe animals pin their ears backwards to protect these fragile but crucial organs from injury. Do you agree or disagree with this theory? Why? | <ul style="list-style-type: none">5. Do cats and dogs communicate in the same ways with their ears as the black bears?6. Why does someone learning to ride a horse need to learn about a horse's ear positions?7. Why might hikers need to be aware of the non-verbal communications bears use with one another? |
|---|--|

RECORD YOUR THOUGHTS:

I HEAR YA!

1. What is the difference between functional and emotional movements of the ears?

Functional - moving ears to focus sounds; emotional - indicating a mood or intent.

2. How might Dr. Kilham have realized that black bears rotate their ears to focus on sounds while eating?

Dr. Kilham may have noticed his bears' ears moving as sounds moved around his bears, just as dogs and cats will move their ears.

3. Why do you think bears need to listen while eating?

Bears stay on the alert while eating to defend their territory and ensure the safety of their young.

4. Some scientists believe animals pin their ears backwards to protect these fragile but crucial organs from injury. Do you agree or disagree with this theory? Why?

Invite students to investigate and interpret on their own.

5. Do cats and dogs communicate in the same ways with their ears as the black bears?

Invite students to investigate and interpret on their own.

6. Why does someone learning to ride a horse need to learn about a horse's ear positions?

Horses are capable of throwing their riders if they feel the rider is not "listening," and while most falls are easily brushed off, it is not something we choose to experience every day.

7. Why might hikers need to be aware of the non-verbal communications bears use with one another?

Hikers encountering bears, cougars, or even coyotes in the wild can treat the animals with more respect and avoid confrontations by reading and heeding the messages sent by the animals.

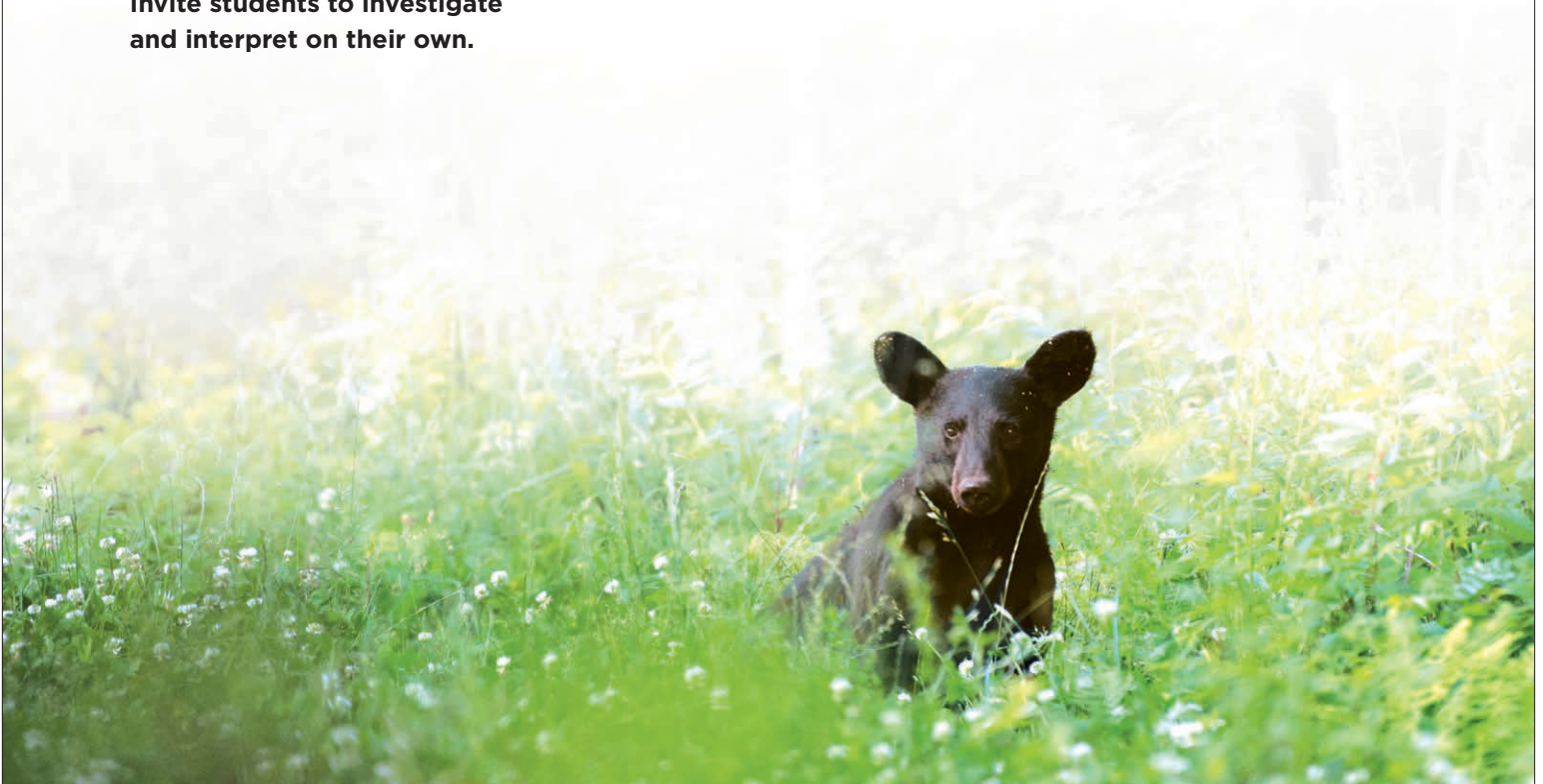

LISTEN TO MY EARS

NON-VERBAL COMMUNICATION

FAMILY ACTIVITY PG 1 OF 1

Name _____

What can **DOGS** teach us?

With a parent or guardian, observe dogs interacting with other animals, either in a dog park, in homes, or even in a dog training class at a pet store or other facility.

Observe and make notes of your findings, then hold a scientists' consortium to discuss your theories with others, just as real scientists do. This may lead to further investigations, and perhaps even a "published" research paper for your class!

THE EARS TELL ALL

- How do dogs indicate a willingness to play?
- How do they indicate aggression, showing another dog who's boss?
- How do they indicate fear or submission?
- How do the dogs use their ears to indicate these messages?

OBSERVATIONS:



WHAT DO YOU SEE?

THE FINE ART OF FIELD OBSERVATION

STUDENT ACTIVITY PG 1 OF 5

Name _____

What would
THE EXPERTS
see?

Keen observation is at the heart of work for many field biologists. Dr. Kilham has spent years patiently watching animals and writing down what he observes. His records include variables like the time of day, time of year, temperature, and even whether or not the wind is blowing. What animal is being observed? What age? Male or female? Is it injured? Is it making a sound

and, if so, what is it like? If the animal hears a sound, does it respond? Does it move its ears or whole head or whole body? How much time does the animal actually spend eating? Remember, we know pandas spend 14-16 hours eating, and to get that data someone had to be watching. Someone like Dr. Jake Owens, the field biologist in the movie *Pandas*.



Dr. Jake Owens with some of his panda friends.

ALWAYS WATCHING

You, as a scientist, need to be very patient and very careful and detailed in writing your field notes. Ready to practice?

Below is a link to five minutes of footage of a panda. How keen are your observation skills? See how good an observer you are and write down everything you observe on the data collection sheet. Then compare your observations to what Dr. Owens noted.

STEP

1

Watch this video:
www.IMAX.com/Observe

STEP

2

Record your observations.

STEP

3

Compare what you recorded to Dr. Owens' observations.

Observation Data Sheets for grades 4-5 are on pages 27 and 28.
Observation Data Sheets for grades 6-8 are on pages 29 and 30.

WHAT DO YOU SEE?

THE FINE ART OF
FIELD OBSERVATION



STUDENT ACTIVITY PG 2 OF 5

PANDA OBSERVATION DATA SHEET FOR GRADES 4-5

DATE: _____

TIME: _____

LOCATION: Chengdu Panda Base

WEATHER: Clear and cool, 14°C

WIND: Calm; A spring morning
at Panda Base Camp

OBSERVER'S NAME: _____

PANDA OBSERVED: Cub (He Yu)

BEHAVIOR TO LOOK FOR:

Is the panda sleeping? Playing? Eating? Are they on the ground, in a tree, in the pool? How close is the cub to the adult panda?

MINUTES : SECONDS

NOTES AND OBSERVATIONS:

:	_____
:	_____
:	_____
:	_____
:	_____
:	_____
:	_____
:	_____
:	_____
:	_____
:	_____
:	_____
:	_____
:	_____
:	_____
:	_____

Add additional pages, if necessary.

WHAT DO YOU SEE?

THE FINE ART OF FIELD OBSERVATION



STUDENT ACTIVITY PG 3 OF 5

PANDA OBSERVATION DATA SHEET FOR GRADES 4-5

DATE: Thursday, April 6, 2018

OBSERVER'S NAME: Jake Owens

TIME: 9:00 am

PANDA OBSERVED: Cub (He Yu)

LOCATION: Chengdu Panda Base

BEHAVIOR TO LOOK FOR:

WEATHER: Clear and cool, 14°C

Is the panda sleeping? Playing? Eating? Are they on the ground, in a tree, in the pool? How close is the cub to the adult panda?

WIND: Calm; A spring morning
at Panda Base Camp

NOTES AND OBSERVATIONS:

MINUTES : SECONDS

- 0 : 15 Mother panda is eating bamboo with piles of bamboo on her stomach
- 0 : 30 Panda cub approaches mother and disturbs her from eating
- 1 : 00 Mother panda bites and pulls cub over to her and plays with her
- 1 : 15 Cub is being moved around and gives out a little yip
- 2 : 15 More mother cub biting and playing, cub getting tired of attention
- 2 : 30 Cub walks away and mother goes back to eating
- 3 : 00 Mother seems to be enjoying her meal
- 3 : 15 Now mother and cub interacting on platform
- 3 : 30 Cub keeps climbing onto mother and makes cute little noises like she is talking to mother
- 4 : 00 Mother and cub keep interacting
- 4 : 15 Cub working to get onto mother
- 4 : 30 Success—cub is getting milk and continues to "talk" about it
- 4 : 45 Mom hangs onto log and plays with cub. Cub keeps making little noises
- 5 : 00 Mom keeps hanging onto log while cub seems to be getting milk. Cub keeps "talking" to Mom

WHAT DO YOU SEE?

THE FINE ART OF FIELD OBSERVATION



STUDENT ACTIVITY PG 4 OF 5

Observer: _____

Date: _____

Focal panda: Cub (He Yu)

PANDA OBSERVATION DATA SHEET

FOR GRADES 6-8

INTERVAL up to minutes : seconds	BEHAVIOR	LOCATION	PROXIMITY TO ADULT	NOTES AND OBSERVATIONS
0 : 15				
0 : 30				
0 : 45				
1 : 00				
1 : 15				
1 : 30				
1 : 45				
2 : 00				
2 : 15				
2 : 30				
2 : 45				
3 : 00				
3 : 15				
3 : 30				
3 : 45				
4 : 00				
4 : 15				
4 : 30				
4 : 45				
5 : 00				

SUMMARY DATA:

I _____	GR _____	C _____
P _____	PO _____	1 _____
E _____	PL _____	2 _____
T _____	T _____	3 _____
IV _____		
D _____		
G _____		
N _____		
OS _____		

KEY

BEHAVIOR:

- I = Inactive
- P = Play
- E = Eat
- T = Travel
- IV = Investigate
- D = Defecate
- G = Groom
- N = Nurse
- OS = Out of Sight

LOCATION:

- GR = Ground
- PO = Pool
- PL = Platform
- T = Tree

PROXIMITY:

- C = Contact
- 1 = <1 meter
- 2 = 1-2 meters
- 3 = >2 meters

WHAT DO YOU SEE?

THE FINE ART OF FIELD OBSERVATION



STUDENT ACTIVITY PG 5 OF 5

Observer: Jake Owens

Date: 4/6/18

Focal panda: Cub (He Yu)

PANDA OBSERVATION DATA SHEET FOR GRADES 6-8

INTERVAL up to minutes : seconds	BEHAVIOR	LOCATION	PROXIMITY TO ADULT	NOTES AND OBSERVATIONS
0 : 15	T	GR	C	Mother panda is eating bamboo with piles of bamboo on her stomach.
0 : 30	P	GR	C	Panda cub approaches mother and disturbs her from eating.
0 : 45	P	GR	C	Mother panda bites cub on head and pulls her over to her.
1 : 00	P	GR	C	Mother panda bites and pulls cub over to her and plays with her.
1 : 15	P	GR	C	Cub is being moved around and gives out a little yip.
1 : 30	P	GR	C	Mother and cub still playing.
1 : 45	P	GR	C	Mother continues to grab cub and bite her.
2 : 00	P	GR	C	Mother bites cub on ears.
2 : 15	P	GR	C	More mother cub biting and playing cub getting tired of attention.
2 : 30	T	GR	3	Cub walks away and mother goes back to eating.
2 : 45	OS	GR	3	Mother uses paws and special "thumb" to manipulate bamboo.
3 : 00	P	PL	C	Mother seems to be enjoying her meal.
3 : 15	P	PL	C	Now mother and cub interacting on platform. Cub tries to get onto mother's stomach.
3 : 30	P	PL	C	Cub keeps climbing onto mother and makes cute little noises like she is talking to mother.
3 : 45	P	PL	C	Cub keeps whimpering and mother is trying to place cub on her to get milk.
4 : 00	P	PL	C	Mother and cub keep interacting.
4 : 15	N	PL	C	Cub working to get onto milk; mother is helping to position cub.
4 : 30	P	PL	C	Success—cub is getting milk and continues to "talk" about it.
4 : 45	N	PL	C	Mom hangs onto log and plays with cub. Mother keeps manipulating cub. Cub keeps making little noises.
5 : 00	N	PL	C	Mom keeps hanging onto log while cub seems to be getting milk. Cub keeps "talking" to Mom.

SUMMARY DATA:

I	<u>0</u>	GR	<u>11</u>	C	<u>18</u>
P	<u>14</u>	PO	<u>0</u>	1	<u>0</u>
E	<u>0</u>	PL	<u>9</u>	2	<u>0</u>
T	<u>2</u>	T	<u>2</u>	3	<u>2</u>
IV	<u>0</u>				
D	<u>0</u>				
G	<u>0</u>				
N	<u>3</u>				
OS	<u>1</u>				

KEY

BEHAVIOR:

I = Inactive
 P = Play
 E = Eat
 T = Travel
 IV = Investigate
 D = Defecate
 G = Groom
 N = Nurse
 OS = Out of Sight

LOCATION:

GR = Ground
 PO = Pool
 PL = Platform
 T = Tree

PROXIMITY:

C = Contact
 1 = <1 meter
 2 = 1-2 meters
 3 = >2 meters

EASY DOES IT

ANIMAL INTERACTIONS
ACTIVITY FOR FAMILIES

HOW DO OUR BODY MOVEMENTS AFFECT THE BEHAVIOR OF OUR ANIMAL NEIGHBORS?

EDUCATOR INFORMATION

Dr. Kilham makes interacting with wildlife look easy and safe. If he can do it, why can't we? Well, it is not safe to approach wild animals! Dr. Kilham has studied these animals for years. He lives by the idea of "Build Trust," and he has learned, sometimes the hard way, to understand their "language" and their "rules." While we cannot expect to approach any wild animal safely, we can use some of his methods to get closer to our safe wild neighbors, the birds and squirrels in our neighborhoods.

Challenge students to practice Dr. Kilham's slow and gentle patience when they approach a wary animal, or even a child, and observe the difference compared to approaching with quick body movements.

Allow students to create their own inquiry, or provide a more directed activity using the following page for guidance. For safety purposes, this would be an excellent family activity, as approaching an animal should always be done in the presence of a parent or other adult.

Remind students: Safety first!



EASY DOES IT!

ANIMAL INTERACTIONS

FAMILY ACTIVITY PG 1 OF 2

Name _____

Meet a NEW FRIEND

In the IMAX film *Pandas*, Dr. Kilham and Hou Rong are seen walking with slow, patient, deliberate steps as they approach one of Dr. Kilham's orphaned black bear cubs. While this would be extremely dangerous with most wild animals, Dr. Kilham knows he can approach the familiar cub. He also sees the cub is wary of Hou Rong, a stranger to the cub. He and Hou Rong use their voices and their body movements to build trust in the cub. While we should always respect any wild animals' space, can we use his methods to get closer to our safe "wild" neighbors, like the birds and squirrels in our neighborhoods?

Note: For safety, have an adult with you who is familiar with the wildlife in your area. Be certain to ask permission of owners before approaching any unfamiliar dogs.



SLOW AND STEADY

QUESTION:

How does a slow, quiet, and patient approach affect the behavior of our animal neighbors?

HYPOTHESIS:

I predict that approaching an animal slowly, quietly, and patiently will... (*choose one*):

_____ build trust, allowing an animal to feel safe

- OR -

_____ frighten the animal, causing it to flee

PROCEDURE:

In an area where you are likely to find birds or squirrels, or in a dog park if you find dogs you can trust (after checking with their humans), try approaching animals with one of two methods: quick movements, or slow and quiet easy-does-it behavior. Carefully observe the behavior of the animals. In which situation do animals exhibit trust? In which situations do animals flee? How many more animals will allow you to approach if you are patient and quiet?

**EASY
DOES IT!**
ANIMAL INTERACTIONS



FAMILY ACTIVITY PG 2 OF 2

Name _____

RESULTS:

- How did the animals respond?
- Did more animals turn and flee with the quick approach, or with the quiet approach?
- Did more animals allow you to observe them more closely with the quiet approach or the noisy approach?

CRITICAL THINKING:

Discuss these questions with your team.

- Dr. Kilham works to build trust with his bear cubs. How does his behavior toward them build this trust?
- How important is it to treat others, including our animal neighbors with whom we share this planet, with respect?



GET CREATIVE

PANDA PAPER BALLOON



HOW CAN WE ALL HELP IN THE CAUSE FOR THE PANDA? GET INVOLVED!

EDUCATOR INFORMATION

Continue your explorations into the world of the giant panda by challenging your students to create a panda craft project, then by looking into the important panda research conducted by the Global Cause Foundation at www.gcause.org.



GET CREATIVE

PANDA PAPER BALLOON

STUDENT ACTIVITY PG 1 OF 6

Name _____

Make a PAPER PANDA

In this activity you will learn how to make an origami panda “balloon” like the ones below.

You will need a bit of patience and practice, but you will enjoy your final result.

There are three panda projects included:

- Panda Beginner version with folding guidelines
- Intermediate version without guidelines
- Advanced version with pop up ears

FOLDING FUN

Print out the Panda Beginner version on an 8.5 x 11 inch sheet of white paper, cut along the solid lines, then follow the instructions on the following pages. After you’ve mastered the Beginner, go on to the panda without guidelines, then on to the advanced version with pop-up ears.

As with all origami, be precise in lining up your corners and edges, and crease all folds sharply (the back of the thumbnail works well).

Enjoy your pandas!

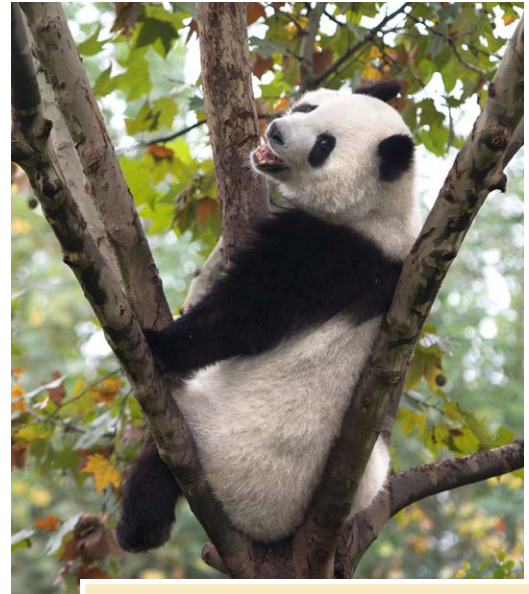

Find creative ways to support Giant Panda populations at Global Cause Foundation: www.gcause.org

GET CREATIVE

PANDA PAPER BALLOON



STUDENT ACTIVITY PG 2 OF 6

Name _____

For all folds, align edges and corners precisely, and crease folds sharply.

Folds 1 and 2: With the paper face down, fold and unfold on the diagonal for each fold to make an X. Crease folds sharply.

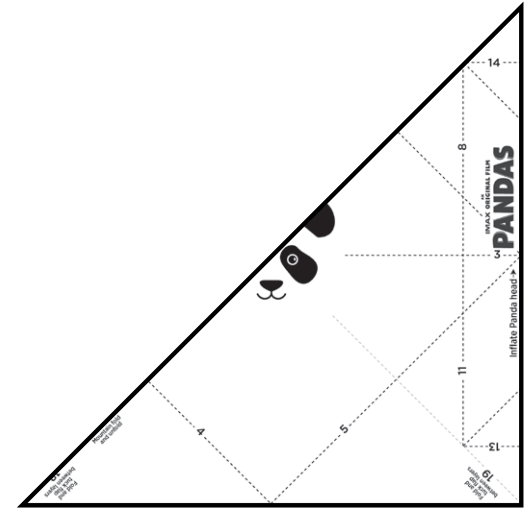
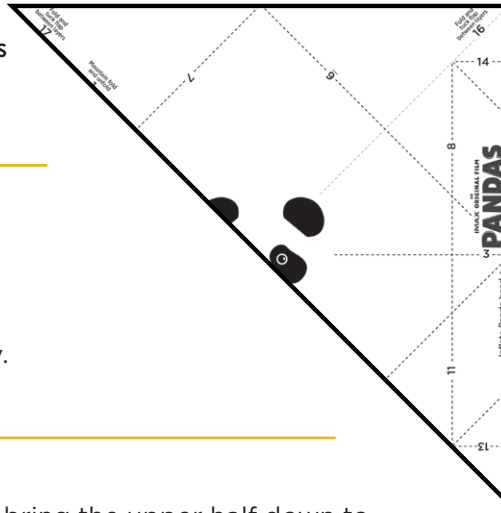

Fold 3: With the paper face up, bring the upper half down to fold in half horizontally. Unfold. With the paper face up again, push the creases from fold 3 backwards. They should pop back toward one another to form a tent-like triangle along the X folds, with the point at the top. Crease folds sharply.

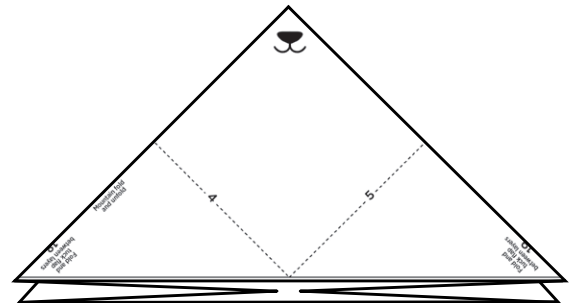
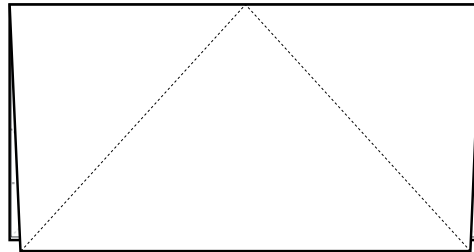

Folds 4, 5, 6 and 7: Bring the top layer's lower left corner up to the center point of the triangle. Repeat for the right corner. Turn over and repeat for folds 6 and 7. After fold 7, the shape will be a diamond.

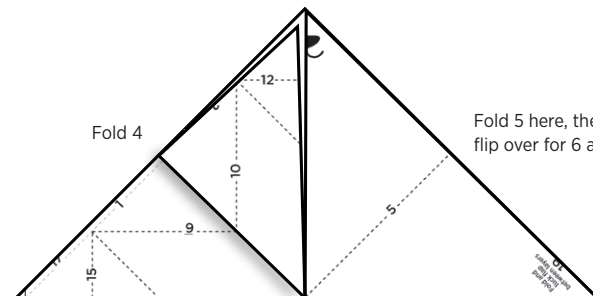

GET CREATIVE

PANDA PAPER BALLOON



STUDENT ACTIVITY PG 3 OF 6

Name _____

Folds 8, 9, 10 and 11: Bring the top layer's outer point in to the center of the diamond for each fold.

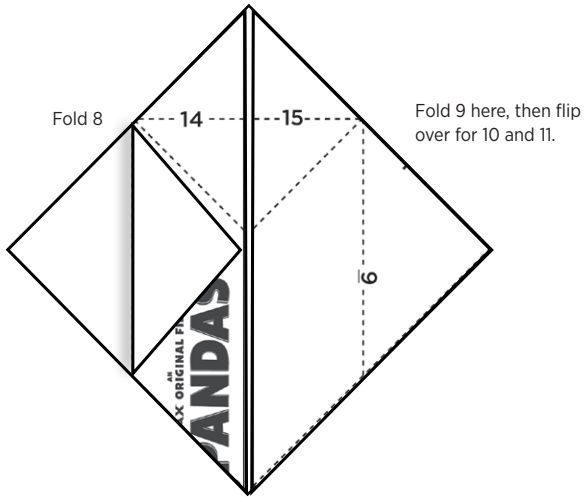

Folds 12, 13, 14 and 15: Bring the top layer's small top point straight down, aligned with the edges from the 8, 9, 10 and 11 folds.

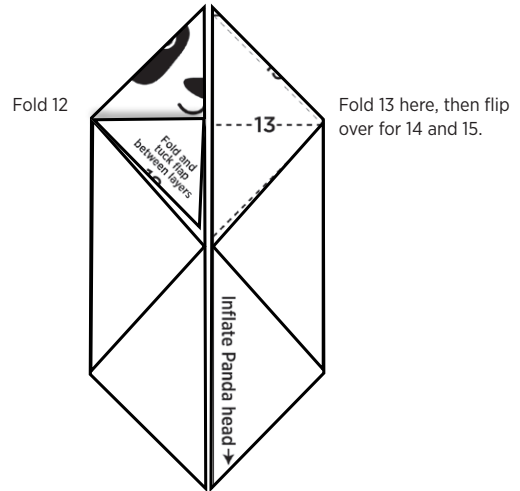

Folds 16, 17, 18 and 19: Fold the small triangles from the 12, 13, 14 and 15 folds down over the side triangles. Tuck the flaps between the layers of the side triangles to lock them in.

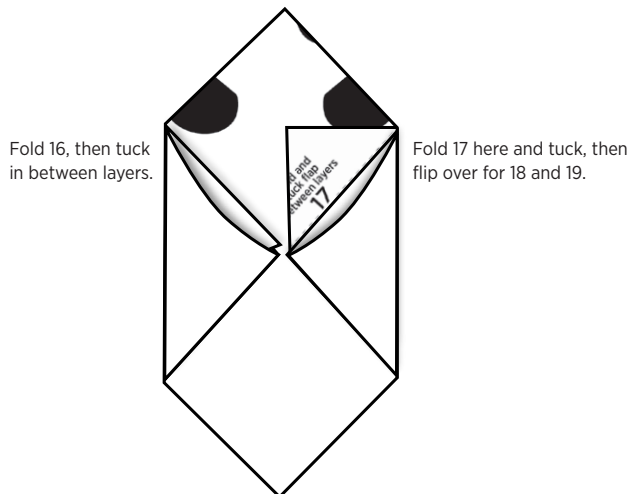

Finally, take a deep breath and blow sharply to inflate the balloon at the opening. (Use dry lips and avoid moistening the paper.) Tug and nudge the corners until the balloon is fully formed. Enjoy your balloon!

Advanced version: After folding, untuck the top flaps part way to give your panda pop-up ears.



Now that you are an experienced Panda Balloon folder, create a panda or other animal of your own!

PANDA PAPER BALLOON

BEGINNER VERSION

ORIGAMI FOLDS:

Mountain fold means the line is visible after creasing (the peaks of the mountain). Only folds 1 and 2 are mountain folds.

Valley fold means the crease is inside (in the valley).

Align edges and corners precisely, and crease folds sharply.



Cut just inside the solid line

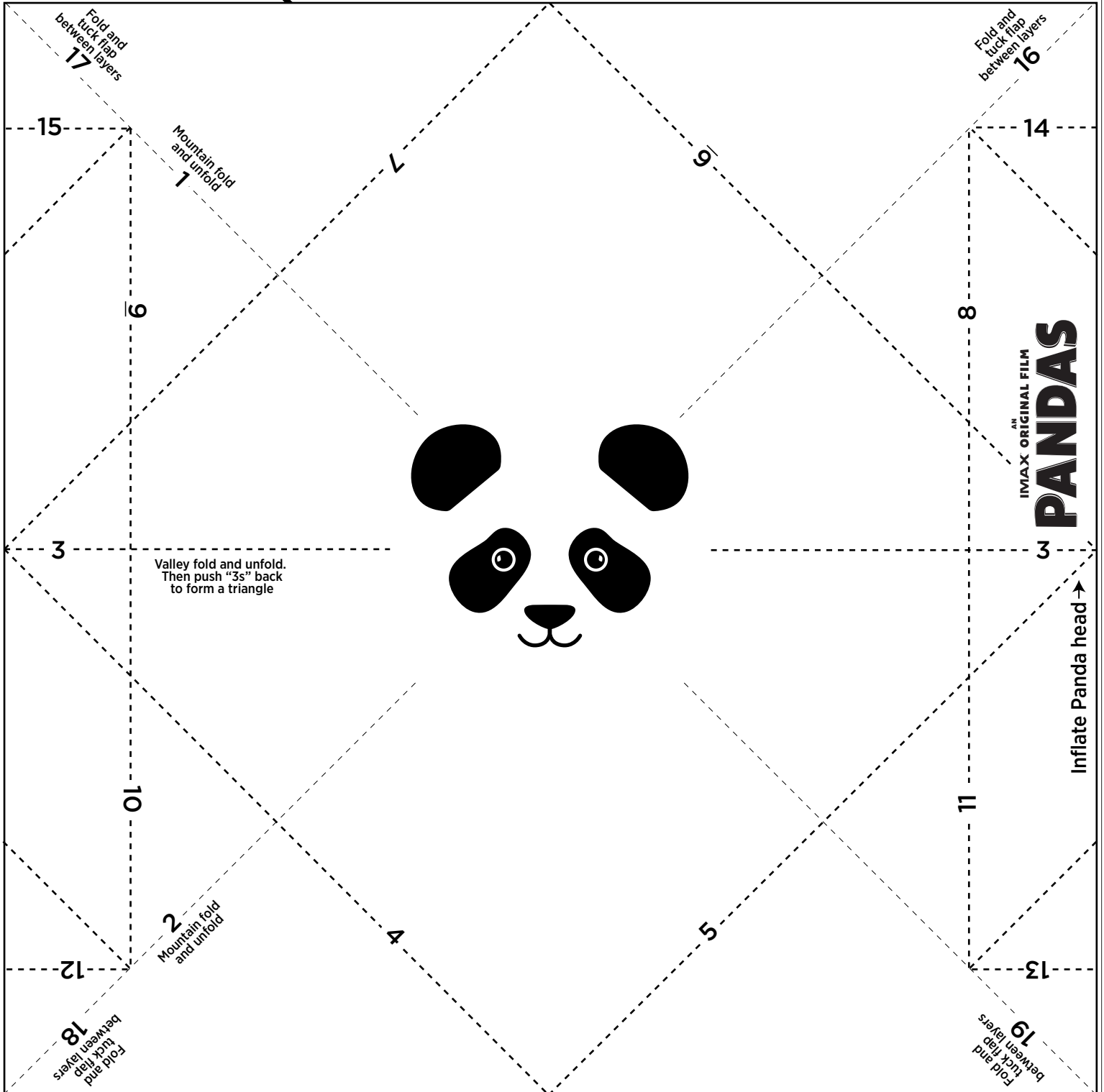

AN IMAX ORIGINAL FILM
PANDAS

Inflate Panda head →

PANDA PAPER BALLOON

INTERMEDIATE VERSION



AN ORIGINAL FILM
PANDAS

PANDA PAPER BALLOON

ADVANCED VERSION

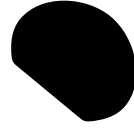
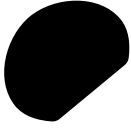

AN
IMAX ORIGINAL FILM
PANDAS

WEB REFERENCES

Giant panda

Global Cause Foundation: www.gcause.org

Black bear

Kilham Bear Center: www.kilhambearcenter.org

WEB REFERENCES FOR MATH ACTIVITIES

Giant panda

www.nationalzoo.si.edu/animals/giant-panda

Black bear

www.env.gov.bc.ca/wat/wq/reference/foodandwater.html#table1

Bengal tiger

www.seaworld.org/animal-info/animal-infobooks/tiger/diet-and-eating-habits

Brown bat

www.nps.gov/shen/learn/nature/big-brown-bat.htm

Cat

www.env.gov.bc.ca/wat/wq/reference/foodandwater.html#table1

Elephant

www.nationalgeographic.com/animals/mammals/a/african-elephant

Giraffe

http://animaldiversity.org/accounts/Giraffa_camelopardalis

Horse

www.env.gov.bc.ca/wat/wq/reference/foodandwater.html#table1

Human

www.nationalgeographic.com/what-the-world-eats

Orca

www.env.gov.bc.ca/wat/wq/reference/foodandwater.html#table1

Rabbit

www.env.gov.bc.ca/wat/wq/reference/foodandwater.html#table1

Red kangaroo

www.redkangaroonutrition.weebly.com/captive-diet.html

For more information and to purchase the book, *In the Company of Bears* written by Benjamin Kilham, please visit:
www.chelseagreen.com/product/in-the-company-of-bears

Acknowledgments:

Pandas activities concepts by:

Diane Carlson, Giant Screen Cinema Consulting, LLC

Pandas activities developed by:

Vicky Latz, Science Educator,
Shoreline School District, Shoreline, WA

Thank you for additional assistance to:

Jacob Clark Blickenstaff PhD, Next Generation
Science Standards (NGSS) Consultant

Ron Smith, Environmental Science Teacher,
Haddonfield Memorial High School

Professor James R. Spotila, Drexel University
& Vice-President Global Cause Foundation

Photo credits:

iStock, page 4

holeintheclouds.net/cute-baby-animal-does-pushups

Shutterstock, page 25

Vicky Latz, panda balloons page 34, 35, 37

Educational Use Only. NOT FOR RESALE.

© 2018 IMAX CORPORATION

NARRATED BY **KRISTEN BELL**

AN

IMAX ORIGINAL FILM

PANDAS

IMAX ENTERTAINMENT PRESENTS IN ASSOCIATION WITH IMAX DOCUMENTARY FILMS CAPITAL, JIN YI CULTURE INVESTMENT (HK) AND PANDA PRODUCTIONS "PANDAS"

NARRATED BY **KRISTEN BELL** DIRECTOR OF PHOTOGRAPHY **DAVID DOUGLAS** EDITOR **BETH SPIEGEL** SOUND DESIGNER **GUS KOVEN** MUSIC BY **MARK MOTHERSBAUGH**
EXECUTIVE PRODUCERS **LI XIAO DONG** **DAVID HARING** AND **ELIE SAMAHA** PRODUCED BY **DREW FELLMAN** **DONALD KUSHNER** AND **STEVE RANSOHOFF**
WRITTEN BY **DREW FELLMAN** DIRECTED BY **DAVID DOUGLAS** AND **DREW FELLMAN**

IMAX

© 2018 IMAX Corp.
IMAX® is a registered trademark of IMAX Corporation.

G GENERAL AUDIENCES
All Ages Admitted

WARNER BROS. PICTURES
© 2018 Warner Bros. Ent. All Rights Reserved

